



**VERSATILITY**

Great in rough terrain, sandy areas and wetlands. Has Hi-Flow for all types of accessories.

**UNSTOPPABLE POWER**

Thanks to the excellent relationship between the engine's power and the hydraulic pump capacity, the ECM tracked skid steer ETL 160.4 has more performance and is unstoppable in tough conditions.

It has high traction force, greater thrust, greater stability, greater output, high lifting capacity, outdoes our competitors!

Big performances on all terrains.



Thanks to the sliding door, access to driver's seat is quick and immediate, without obstacles.

**COMFORT / VISIBILITY**

The new generation of ECM skid steers has been studied and manufactured in order to guarantee the operator satisfaction. Servo controlled joysticks offer a full control of movements that become fast and immediate, requiring the least effort. The driver's seat is spacious and comfortable with double security bar, it is in an advanced position and it allows a perfect visibility of the operative field during every work phase, even while unloading. This is due to the fact that the dashboard with diagnostic instruments is placed at the joysticks side. Closed cabin (optional) with heating system or air-conditioning increases the machine use possibilities under every climatic condition.



**MAINTENANCE / FILLING UP POINTS**

All there is to do is to open the rear panel and everything is within reach in order to carry out the simple but important maintenance operations without difficulties or waste of time (all filters can be reached easily). For ease of cleaning the oil-cooler it has a new system of half-opening allowing the partial division of the oil-cooler from the rest of the engine. The total accessibility to the inside of the machine is possible thanks to the cabin lifting up making inspection easy to the diesel engine, and transmission components, the whole hydraulic system, and simple and easy access to fuel and hydraulic oil supply tanks.

**ETL 160.4**

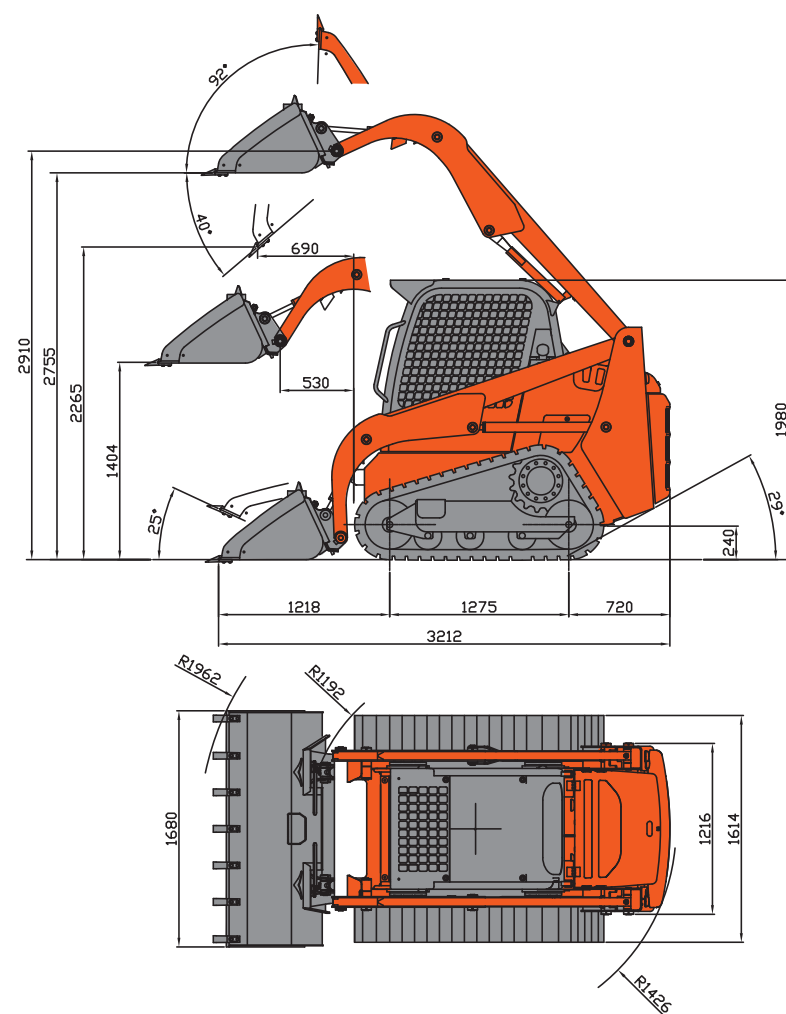

**STEEL TRACKS INSTALLATION**

Every tracked skid loader ETL 160.4 manufactured with rubber tracks can be equipped in every moment with steel tracks. There are just to replace the bottom rollers, the sprocket, the idlers and to insert a carrier roller with relevant collar.

**ENGINE**

Manufacturer:	CUMMINS B3.3NA - EU Stage II
Type:	Aspirated with indirect injection
Max power:	48 kW (65.3 HP) at 2600 rpm
	SAE J1995
Max torque:	214 mxN at 1600 rpm - SAE J1995
Displacement:	3300 cc
Cylinders n°:	4 in line
Cooling system:	water
Filtering:	dry, with main cartridge, security and obstruction gauge

**TRANSMISSION**

Type:	Hydrostatic with double pump and gearboxes on the wheels type TRASMITAL-KAYABA
Speed:	I <sup>o</sup> : 0÷6 km/h - II <sup>o</sup> : 0÷12 km/h
Traction force:	I <sup>o</sup> : 3800 daN - II <sup>o</sup> : 2430 daN
Rubber tracks:	320 mm
Steel tracks:	300 mm

**CONTROLS**

Type:	Ergonomic joystick with security block on board
Translation:	Driven by left joystick
Services:	Driven by right joystick for lifting and bucket

Arrangement for fittings (standard): Electrohydraulic with detent; 60 lt/min at 190 bar  
Lifting mechanism: Self-levelling system for bucket (standard)

**BRAKES**

Service brakes: hydrostatic  
Parking brakes: negative with multiple disks into oil bath, integrated on the rear gearboxes at electrohydraulic control  
Emergency brakes: electrohydraulic, acting on the parking brakes (integrated on the rear gearboxes)

**ELECTRIC SYSTEM**

Battery:	12 V - Ah 80/550
Alternator:	12 V - 60 A

**HYDRAULIC SYSTEM**

Pump:	n.1 with gears for services
Max capacity:	l/1' 60
Pressure:	bar 190
Distributor:	controlled by joystick "combined type"

**CAPACITIES**

Engine oil:	kg	7.5
Water coolant:	l.	18
Fuel tank:	l.	70
Hydraulic oil tank:	l.	55
Hydraulic circuit:	l.	15

**LIFTING DATA**

Useful carrying capacity 4 in 1 Bucket:	1200 kg - 0.325 m3
Upsetting load:	kg 2200
Shovel width:	mm 1680
Weight with rubber trucks:	kg 3400
Weight with steel tracks:	kg 3700

- ROPS ISO 3471 and FOPS 1st level ISO 3449 homologated cabin
- Front and back working lights



**STANDARD EQUIPMENT**

- CUMMINS 65,3 HP water-cooled engine
- ROPS FOPS canopy with rear and top windows
- Hydrostatic transmission with double pump (variable flow)
- Universal quick coupling plate (for bucket and equipments)
- Front bucket capacity m3 0,45 and width mm 1680
- Adjustable seat with seat belt and safety bar
- Self-levelling system (acting on slope only)
- N. 1 rear working light
- Magnetic rotating lamp
- Rear view mirrors right and left
- 12V electric outlet
- Accelerator by pedal and/or lever

- Electrohydraulic automatic handbrake
- Tool box with spare parts catalogue and use and maintenance manual



- Electrohydraulic high flow (120lt/min at 190 bar) for accessories
- 4 in 1 bucket
- Sliding side windows for canopy
- Fixed side windows for canopy
- Closed cabin with sliding side windows and door with windscreen wiper and heating or air conditioning system
- Floating system
- Reverse buzzer
- Rear additional ballasts

Engine	CUMMINS B3.3NA
Displacement	cc 3300
Max power Kw	48 - Hp 65,3
Weight Kg	3400 - Kg 3700



PO Box 709, Toukley NSW 2263  
 Ph: 0418 434 554  
[shaun@minies.com.au](mailto:shaun@minies.com.au) | [www.minies.com.au](http://www.minies.com.au)

**Tracked Loader**